

PYRP500-XA (蠕动泵)

蠕动泵

LIQUID PUMP



典型应用 Typical Applications

- Home appliances, medical, beauty, massage, adult products
家用电器.医疗.美容.按摩.成人用品.
- Hand sanitizer foaming machine
洗手液发泡机

外形尺寸

Dimension

WEIGHT:56.0g(APPROX)
UNIT:MILLIMETERS

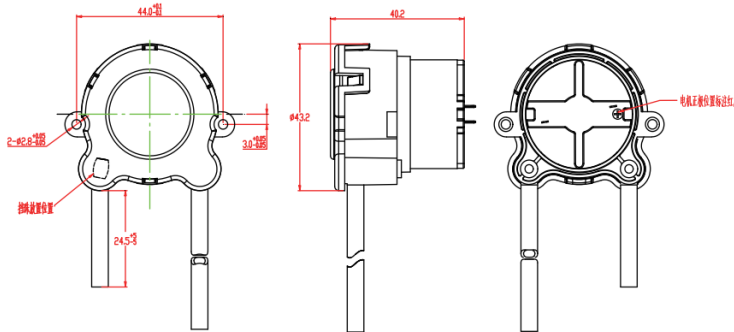

产品规格

Product Specifications

额定电压 Rated Voltage	DC 3V	DC 3.7V	DC 4.5V	DC 6V	DC 12V
额定电流 Rated Current	≤ 800mA	≤ 650mA	≤ 530mA	≤ 400mA	≤ 200mA
功率 Power	2.4 W	2.4 W	2.4 W	2.4 W	
气嘴口径 Air Tap O.D.	Ø5.0mm				
抽液量 Water flow	100-300 mLPM				
最大真空度 Maximum Vacuum	≤ -20 Kpa(-150mmHg)				
噪音 Noise Level	≤ 65db (30cm away)				
寿命测试 Life Test	≥ 100,000 Times (ON 2秒, OFF 2秒)				
扬程 Pump Head	≥ 0.5m				
吸程 Suction Head	≥ 0.5m				
重量 Weight	56g				

* Other parameters: according to customer demand for design/其他参数：根据客户的需求设计.